



SUN-BATT-5.32

Product Description

Sunsynk UK Ltd.

7 Abbey Square, Chester CH1 2HU, England.

+852-2884 4318 +852-2884 4816 support@sunsynk.com www.sunsynk.org

CONTENTS

1	Technical Data	1-2
2	Product Overview	3
2.1	Brief Introduction	3
2.2	Interface Introduction	4
2.2.1	Switch ON/OFF	4
2.2.2	LED Indicator Definition	5
2.2.3	CAN / RS485 Port	6
2.2.4	RS232 Port	6
3	Installation Guide	7
3.1	Checking Before Installation	7
3.1.1	Checking Outer Packing Materials	7
3.1.2	Checking Deliverables	7-8
3.2	Tools	9
3.3	Installation requirements	9
3.3.1	Installation environment requirements	9
3.3.2	Installation carrier requirements	10
3.4	Installation Instructions	10
3.4.1	Dimensions	10
3.4.2	Installation Procedure	11-14
4	Maintenance	15
4.1	Recharge Requirements During Normal Storage	15
4.2	Recharge Requirements When Over Discharged	16

01

TECHNICAL DATA

NOTE

Operating current derating according to cell voltage and battery temperature.



Performance	
Nominal Voltage	51.2 Vdc
Nominal Capacity	104Ah
Battery Energy ¹	5320 Wh
Charge Voltage	55.68-56.16Vdc
Discharge Voltage	45.6-56.16 Vdc
Nominal Charge/Discharge Current	50A
Nominal Charge/Discharge Power	2500W
Max Charge / Discharge Current	100A
Max Charge / Discharge Power	5000W
Short Circuit Current	350A
Communication	
Display	SOC status indicator, LED indicator
Communication	RS232、RS485、CAN
General Specification	
Dimension(W×D×H mm)	450×150×533mm
Weight (Kg)	45kg
Installation	Floor stand or Wall mounted
Working Temperature ²	-20°C ~ 60°C
Storage Temperature	≤25°C,12 months; ≤35°C,6 months; ≤45°C,3 months
Operating / Storage / humidity	≤ 95%RH
Max Operating Altitude	≤2000m
IP Rating	IP20
Cell Technology	LiFePO ₄ , Lithium Iron Phosphate
Cycle life ³	6000 Cycles @ 80% DOD / 25°C / 0.5C, 60% EOL
Scalability	Max 8 batteries in parallel
Standard Compliance	
Certification	PACK:UN38.3、IEC62619、IEC61000 CELL:UN38.3、IEC62619、UL 1642、JET (more available upon request)
Ordering and Deliverable Part	
Product ordering part	SUN-BATT-5.32 battery SUN-BATT-5.32 parallel cable SUN-BATT-5.32 to PCS cable

1. Test conditions: 100% depth of discharge (DoD), 0.2C rate charge & discharge at 25°C

2. Charge/discharge derating occurs when the operating temperature from -10°C to 5 °C & 45 °C to 55 °C.

3. Condition apply. Refer to SUN-BATT-5.32 Warranty Letter

02

PRODUCT OVERVIEW

2.1 Brief Introduction

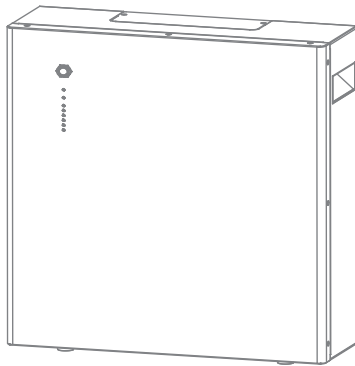

PRODUCT OVERVIEW

SUN-BATT-5.32 is a lithium battery with an operating voltage range between 45.6~56.16V. It is designed for residential energy storage applications and works together with a 48v battery hybrid inverter. **SUN-BATT-5.32 is not suitable for supporting life-sustaining medical devices.**

SUN-BATT-5.32 has built-in BMS (Battery Management System), which can manage and monitor cells information including voltage, current and temperature. Besides that, BMS can balance cells charging to extend cycle life. BMS has protection functions including over-discharge, over-charge, over-current and high/low temperature; the system can automatically manage charge state, discharge state and balance state.

Multiple SUN-BATT-5.32 can be connected in parallel to expand capacity and power, 8 SUN-BATT-5.32 can be connected in parallel at most.

2.2 Interface Introduction

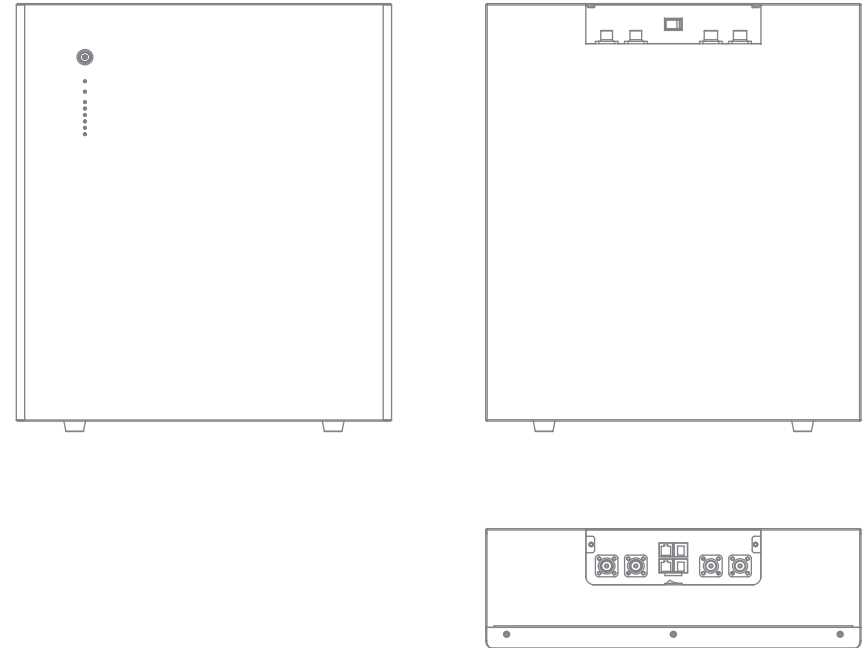

2.2.1 Switch ON/OFF

1. Switch ON

For single SUN-BATT-5.32, switch ON rocker switch (near positive/negative connector), then long press (more than 3 seconds) ON/OFF button on front panel, LED will flash then battery will operate normally. L1 to L6 shows battery SOC, L7/L8 shows battery status.

For multiple SUN-BATT-5.32 in parallel, switch ON rocker switch on all batteries, long press (more than 3 seconds) ON/OFF button of MASTER battery, LED will flash, battery system will automatically encode and assign ID to each slave battery, then battery system will operate normally.

2. Switch OFF

Press start button of Master PACK more than 3s and then release the button, the master pack will shut down after all slave packs shut down(Sleep mode) .

For single SUN-BATT-5.32, switch OFF rocker switch (near positive/negative connector).

For multiple SUN-BATT-5.32 in parallel, switch OFF rocker switch on MASTER battery first. Then switch OFF rocker switch on all slave batteries.

2.2.2 LED Indicator Definition

Note:

flash 1 - 0.25s light / 3.75s off

flash 2 - 0.5s light / 0.5s off

flash 3 - 0.5s light / 1.5s off

LED Indicators Instructions

Status	RUN	ALM	Battery Level Indicator						Descriptions	
	L8	L7	L6	L5	L4	L3	L2	L1		
Shut down	OFF	OFF	OFF	OFF	OFF	OFF	OFF	OFF	AI OFF	
Standby	Flash 1	OFF	According to the battery level						Indicates Standby	
Charging	Normal	Light	OFF	According to the battery level						The highest capacity indicator LED flashes(flash 2),others lighting
	Full Charged	Light	OFF	Light	Light	Light	Light	Light	Light	Turn to standby status when charger off
	Protection	OFF	Light	OFF	OFF	OFF	OFF	OFF	OFF	Stop charging
Discharge	Normal	Flash 3	OFF	According to the battery level						
	UVP	OFF	OFF	OFF	OFF	OFF	OFF	OFF	OFF	Stop charging
	Protection	OFF	Light	OFF	OFF	OFF	OFF	OFF	OFF	Stop discharge
Fault	OFF	Light	OFF	OFF	OFF	OFF	OFF	OFF	Stop charging and Discharge	

Charging Battery Level Indicators Instructions

Status	Charging								
	L8	L7	L6	L5	L4	L3	L2	L1	
Battery Level Indicator									
Battery Level (%)	0~17%	Light	OFF	OFF	OFF	OFF	OFF	Flash 2	
	18~33%			OFF	OFF	OFF	OFF	Flash 2	Light
	34~50%			OFF	OFF	OFF	Flash 2	Light	Light
	51~66%			OFF	OFF	Flash 2	Light	Light	Light
	67~83%			OFF	Flash 2	Light	Light	Light	Light
	84~100%			Flash 2	Light	Light	Light	Light	Light
	Full Charged			Light	Light	Light	Light	Light	Light

Discharging Battery Level Indicators Instructions

Status	Discharge							
Battery Level Indicator	L8	L7	L6	L5	L4	L3	L2	L1
Battery Level Indicator								
Battery Level (%)	Flash 3	OFF	OFF	OFF	OFF	OFF	OFF	Light
			OFF	OFF	OFF	OFF	Light	Light
			OFF	OFF	OFF	Light	Light	Light
			OFF	OFF	Light	Light	Light	Light
			OFF	Light	Light	Light	Light	Light
			Light	Light	Light	Light	Light	Light

2.2.3 CAN / RS485 Port

CAN / RS485 Communication Terminal (RJ45 port), connect to inverter, follow CAN / RS485 protocol.

PIN	Definition
Pin 1、 Pin 8	RS485-B (to PCS, reserved)
Pin 2、 Pin 7	RS485-A (to PCS, reserved)
Pin 3	NC
Pin 4	CANH (to PCS)
Pin 5	CANL (to PCS)
Pin 6	GND

2.2.4 RS232 Port

RS232 Communication Terminal (RJ45 port) follow RS232 protocol, for manufacturer or professional engineer to debug or service.

PIN	Definition
Pin 1、 Pin 8	GND
Pin 2、 Pin 7	RS232_TX
Pin 3、 Pin 6	RS232_RX
Pin 4、 Pin 5	NC

03

INSTALLATION GUIDE

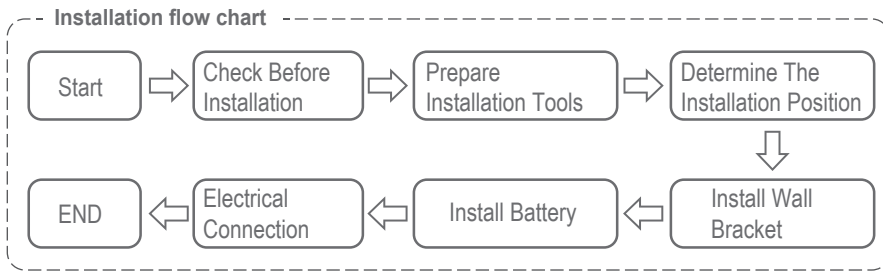
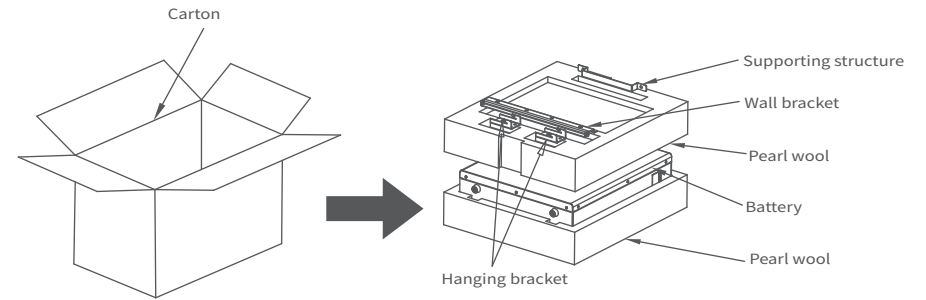

3.1 Checking Before Installation

3.1.1 Checking Outer Packing Materials

Packing materials and components may be damaged during transportation. Therefore, check the outer packing materials before installing the battery. Checking the surface of packing materials for damage, such as holes and cracks. If any damage is found, do not unpack the battery and contact the dealer as soon as possible. You are advised to remove the packing materials within 24 hours before installing the battery.











3.1.2 Checking Deliverables

After unpacking the battery, check whether deliverables are intact and complete. If any damage is found or any component is missed, contact the dealer.

The below table shows the components and mechanical parts that should be delivered.

NO.	Pictures	Quantity	Description
1		1PCS	Battery
2		1PCS	Wall bracket
3		2PCS	Hanging bracket
4		1PCS	Supporting structure
5		4PCS	M8*60
6		8PCS	M6*16
7		2PCS	M4*20
8		1PCS	Manual
9		1PCS	Test report
10		1PCS	Certificate

3.2 Tools

Tools			
Installation	Knife 	Measuring tape 	Socket wrench (10/16mm) 
	Rubber mallet 	Cross Screwdriver 	Hammer drill (8mm) 
Protection	ESD gloves 	Safety goggles 	Anti-dust respirator 
	Safety shoes 		

3.3 Installation requirements

3.3.1 Installation environment requirements

- Install the battery in the indoor environment.
- Place battery in secure location away from children and animals.
- Do not place the battery near any heat sources and avoid sparks.
- Do not expose the battery to moisture or liquids.
- Do not expose the battery to direct sunlight.

3.3.2 Installation carrier requirements

- Only mount battery on fire resistant building. Do not install batteries on flammable buildings.
- Battery is quite heavy, make sure the wall/ground can meet the load bearing requirements.

3.4 Installation Instructions

3.4.1 Dimensions

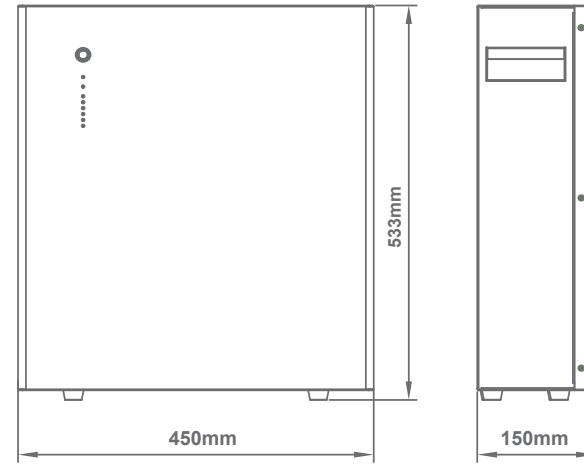

Minimum mounting distance between battery pack and equipment:

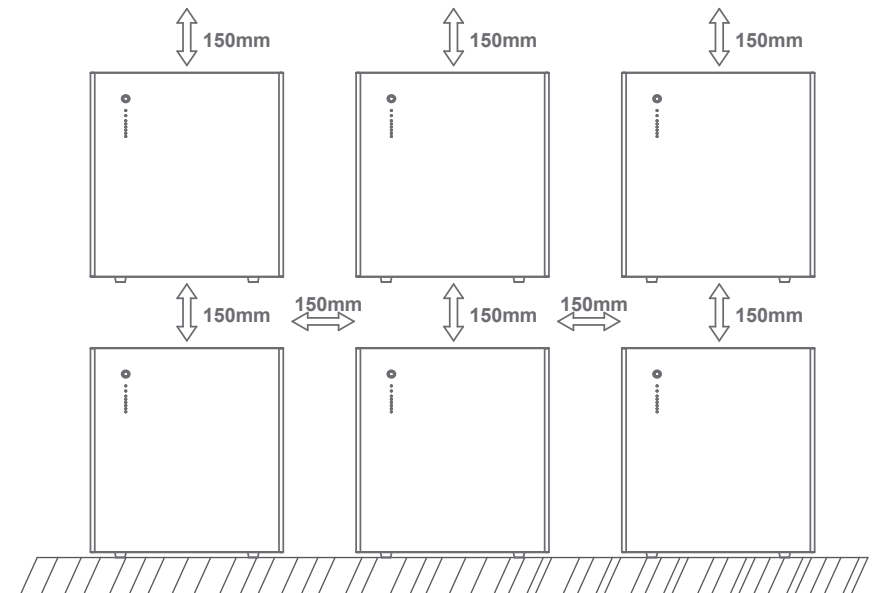

3.4.2 Installation Procedure

STEP 1

Drill the hole with an 10mm drill bit as follows and fix the wall bracket to the wall.

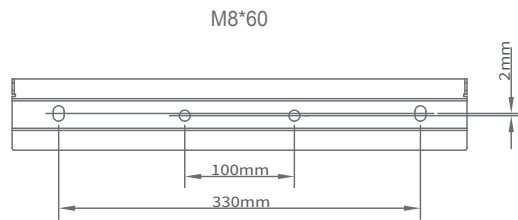

STEP 2

Install the hanging bracket

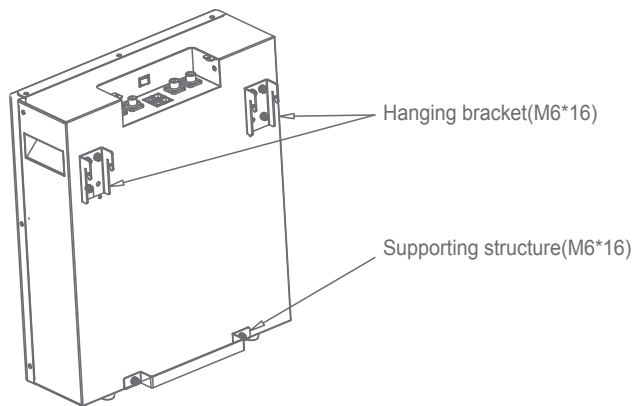

STEP 3

Hang SUN-BATT-5.32 on the wall bracket and tighten it.

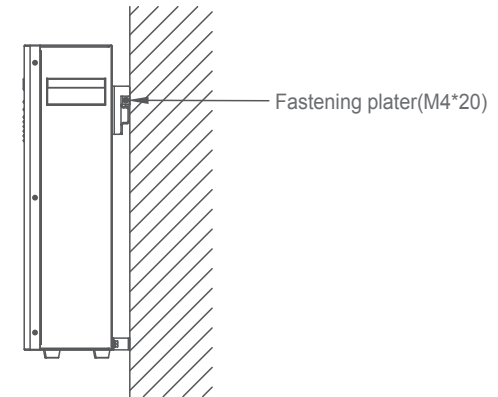

STEP 4

Connect to ground.

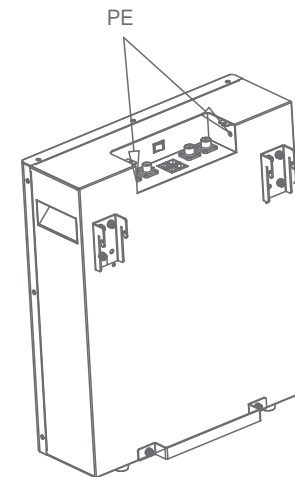

STEP 5

Connect power cable.

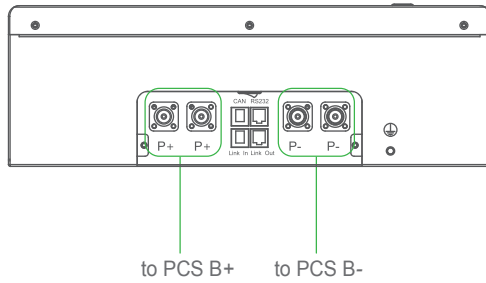

STEP 6

Connect communication cable.

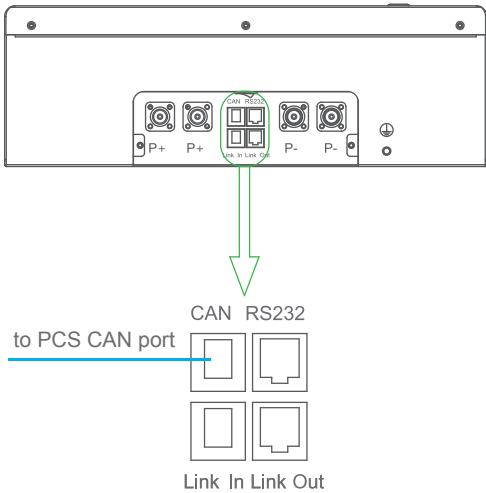

STEP 7

When multiple batteries are connected in parallel, follow the following wiring mode

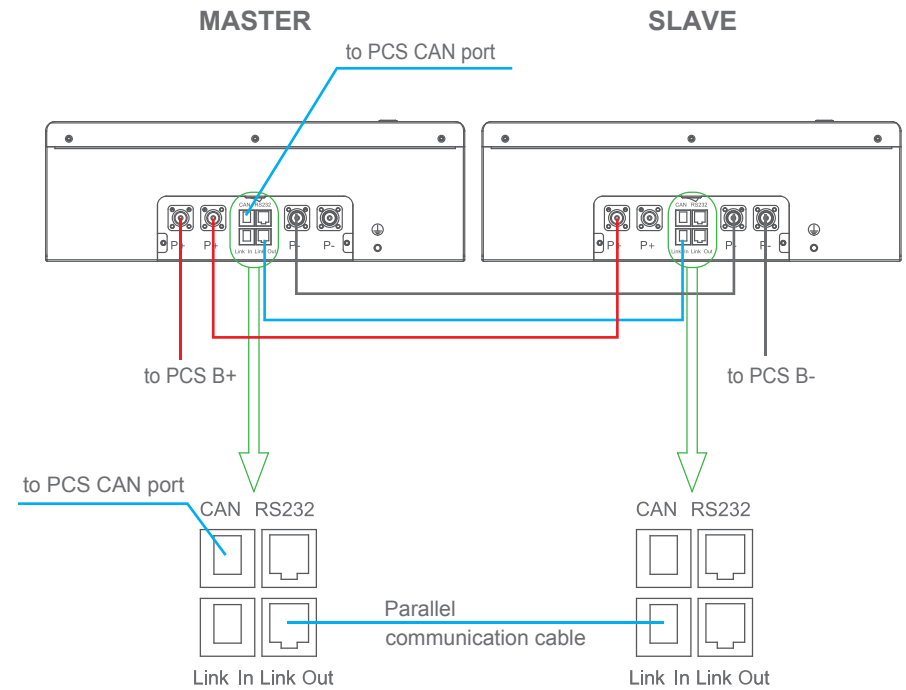

04

MAINTENANCE

4.1 Recharge Requirements During Normal Storage

Battery should be stored in an environment with temperature range between -10°C ~ $+45^{\circ}\text{C}$, and maintained regularly according to following table with 0.5C (25A) current till 40% SOC after long storage time.

Recharge Conditions When In Storage

Storage Environment Temperature	Relative Humidity of Storage Environment	Storage Time	SOC
Below -10	/	prohibit	/
-10~25	5%~70%	≤ 12 months	$30\% \leq \text{SOC} \leq 60\%$
25~35	5%~70%	≤ 6 months	$30\% \leq \text{SOC} \leq 60\%$
35~45	5%~70%	≤ 3 months	$30\% \leq \text{SOC} \leq 60\%$
Above 45	/	prohibit	/

4.2 Recharge Requirements When Over Discharged

Over discharged (90% DOD) battery should be recharged according to following table, otherwise over discharged battery will be damaged.

Recharge conditions when battery is over discharged

Storage Environment Temperature	Storage Time	Note
-10~25	≤ 15 days	Battery Pack disconnected from PCS
25~35	≤ 7 days	
-10~45	<12 hours	Battery Pack connected to PCS